

BFD915WX

90cm, 150L, Freestanding Cooker

BLANCO



Model Code

BFD915WX

Description

90cm, 150L, 5 burner gas cooktop and 8 function oven

Included Accessories

- 3 x anti tip shelves
- 1 x baking tray
- 1 x grill insert
- 1 x set of telescopic runners
- 1 x cast iron wok support trivet
- 1 x stainless steel kick plate
- Propane Conversion kit

Warranty

BLANCOCare™ 2 years parts & labour.

Features

Benefits

150L Grand Capacity

With the largest freestanding oven capacity on the market, the new BLANCO BFD915WX, can cook even the largest feasts, with perfect results every time. The BFD915WX has been designed to make cooking for large groups quick and easy.

BLANCO MultiFan System

The new BLANCO MultiFan system has four fans that present four times the efficiency of a standard freestanding cooker. The four fans guarantee homogeneous heat distribution and affords perfect cooking results every time. Food can be placed on any shelf position or on multiple levels with optimum results achieved.

Dual Fan Elements

In addition to the unique BLANCO MultiFan system, the BFD915WX also features diagonal circular elements. These elements are perfectly designed and calibrated to surround food in a uniform fashion in order to obtain optimum cooking results on all levels.

Automatic Rapid Heat Up

Featuring Automatic Rapid Heat Up the BFD915WX gets to 200°C in a shorter time than any other freestanding cooker on the market. The Automatic Rapid Heat Up is aided by the additional fans and elements and is based on a balance between oven capacity and heat up time versus standard freestanding cookers.

Real Multi-Level Cooking

The unique cavity design of the BFD915WX allows for seven shelf positions and six true cooking levels. This is primarily due to the height of the cavity which allows you to cook multiple trays of food together, unlike standard 90cm cavities, that may be 'large' but not high.

BFD915WX

90cm, 150L, Freestanding Cooker

BLANCO

PRODUCT SPECIFICATIONS:

Method Of Installation:	Freestanding
Dimensions:	900W x 600D x 900 - 920H mm
Dimensions With kickplate:	920H mm
Bench Height:	900H mm
Splashguard:	60H mm
Adjustable Feet:	Yes
Full Plinths:	No

OVEN SPECIFICATIONS:

Capacity (Gross):	150 Litres
Oven Functions:	8 - Fan Forced, Fan Assist, Bottom Element with Fan, Fan Grill, Grill, Traditional, Defrost, Light
Number of Shelf Positions:	7
Oven Controls:	Knob
Fully Programmable Timer:	Yes - Button Control
Layers of Door Glass:	2
Removable Door:	Yes
Closed Door Grilling:	Yes
Warming Drawer:	No
Storage Drawer:	No
Lights:	2
Single Welded Cavity:	Yes
Power Requirements:	240 V, 50/60HZ, 3600 W
Type of Connection:	15 Amp - cable and plug supplied

OVEN ELEMENTS:

Grill Heating Element:	2000W
Circular Heating Element:	1600W x 2
Upper Heating elements:	1400W + 2000W
Lower Heating elements:	1850W
Maximum Power:	3600W

COOKTOP SPECIFICATIONS:

Cooktop Type:	Gas
Number of Burners:	5
Burner Type:	Sabaf burners
Trivets:	Heavy Duty Cast Iron Trivets
Wok Trivet Supplied:	Yes
Removable Trivets:	Yes
Removable Burner Caps:	Yes
Flame Failure:	No
Cooktop Controls:	Knob
Gas Connection Position:	Right hand 30mm - Rear of cooker

COOKTOP POWER:

Cooktop Burners:	Natural Gas	Propane Gas
Wok Burner x 1:	15.0 MJ/h	14.6 MJ/h
Rapid Burner x 1:	10.0 MJ/h	10.0 MJ/h
Semi Rapid Burners x 2:	7.2 MJ/h	7.2 MJ/h
Auxiliary Burner x 1:	4.0 MJ/h	3.8 MJ/h

BFD915WX

90cm, 150L, Freestanding Cooker

BLANCO

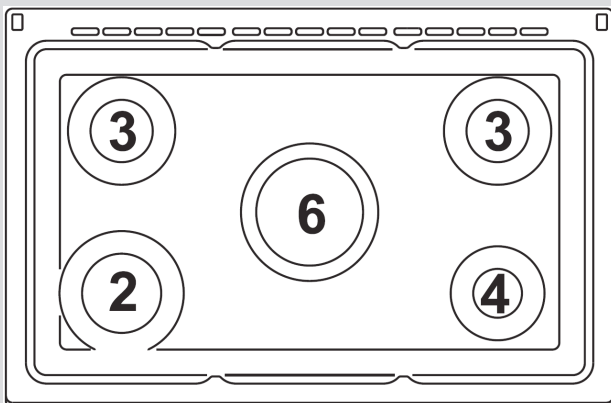
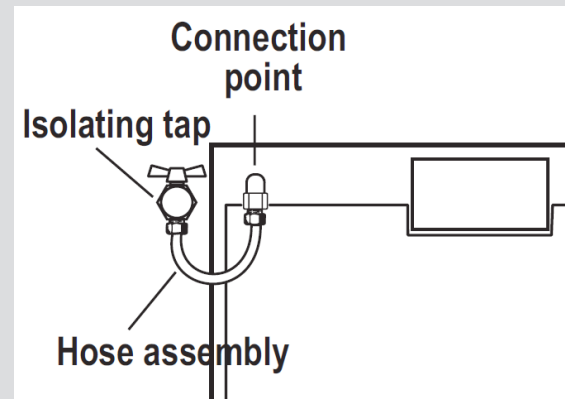
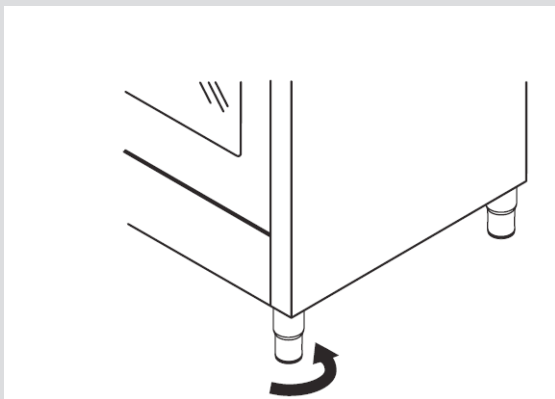
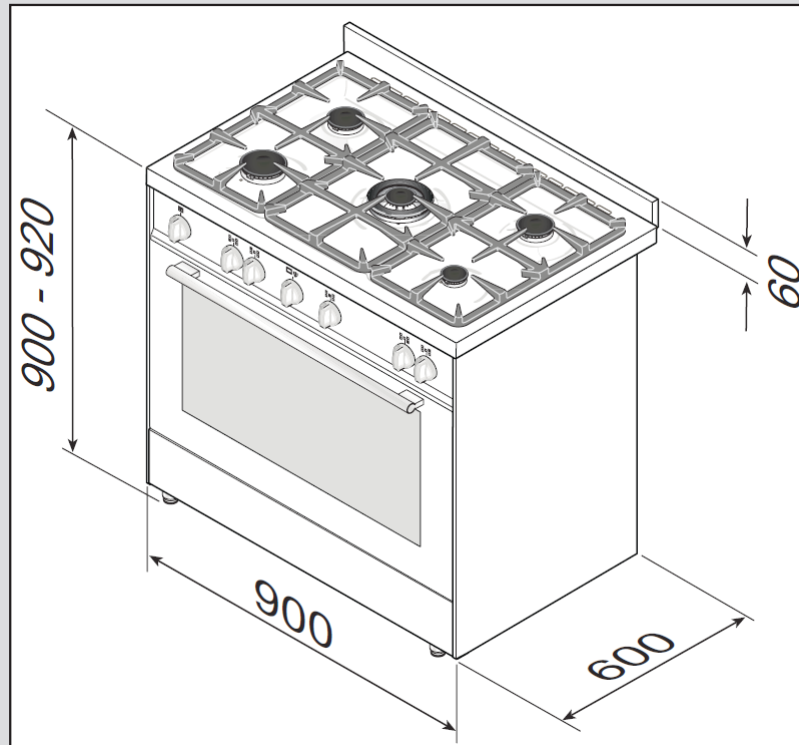

No.	Burner	Position	Gas	Rating MJ/h
2	Rapid	Left Front	U-LPG	10.0
			Natural	10.0
3	Semi-Rapid	Right and Left Rear	U-LPG	7.2
			Natural	7.2
4	Auxillary	Right Front	U-LPG	3.8
			Natural	4.0
6	Wok	Centre	U-LPG	14.6
			Natural	15.0

NOTE 1: It is advisable to check dimensions of physical product when measuring for installation and prior to completing any cut outs.

NOTE 2: Due to continual product development the information provided is not final and may be subject to change.